

STRATEGY PHARMACY

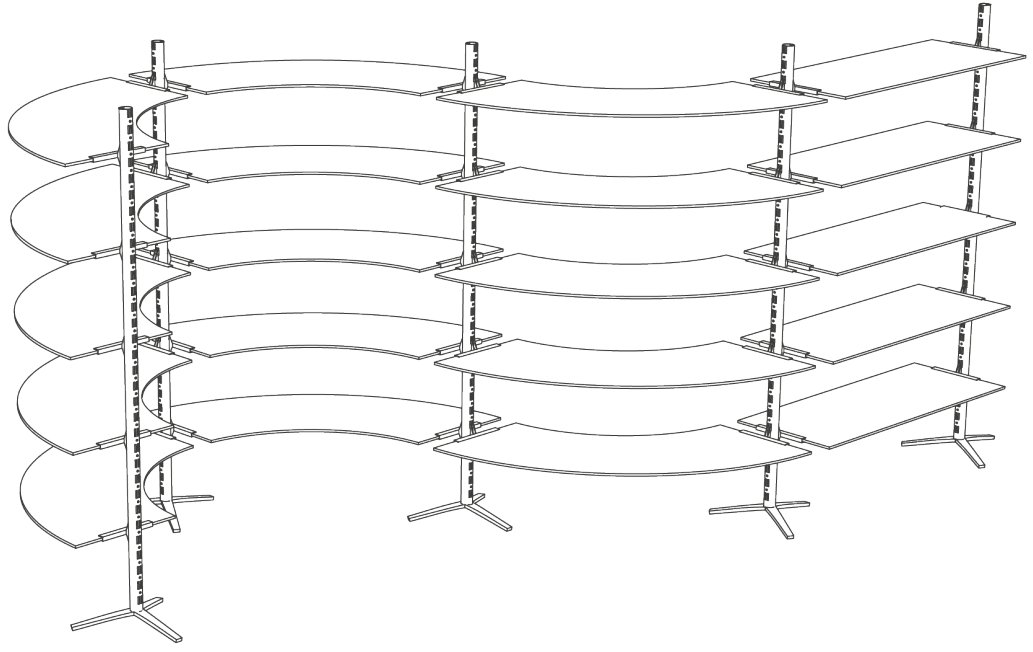

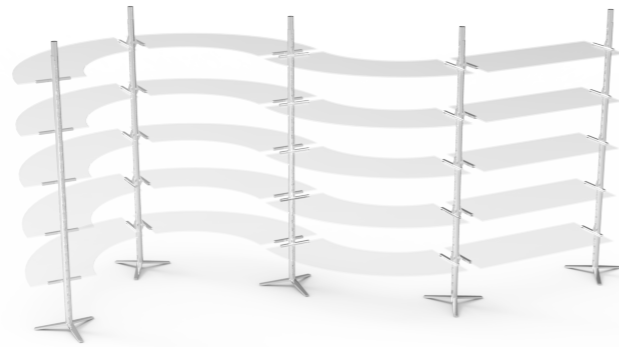

Gondola curva
pag. 4-5



Elementi murali
pag. 6-7



Elementi centrali | vetrina
pag. 8-9



Elementi centrali | vetrina
pag. 10-11



Espositore in metallo
pag.12-13



Scaletta expo Leather
pag. 14-15

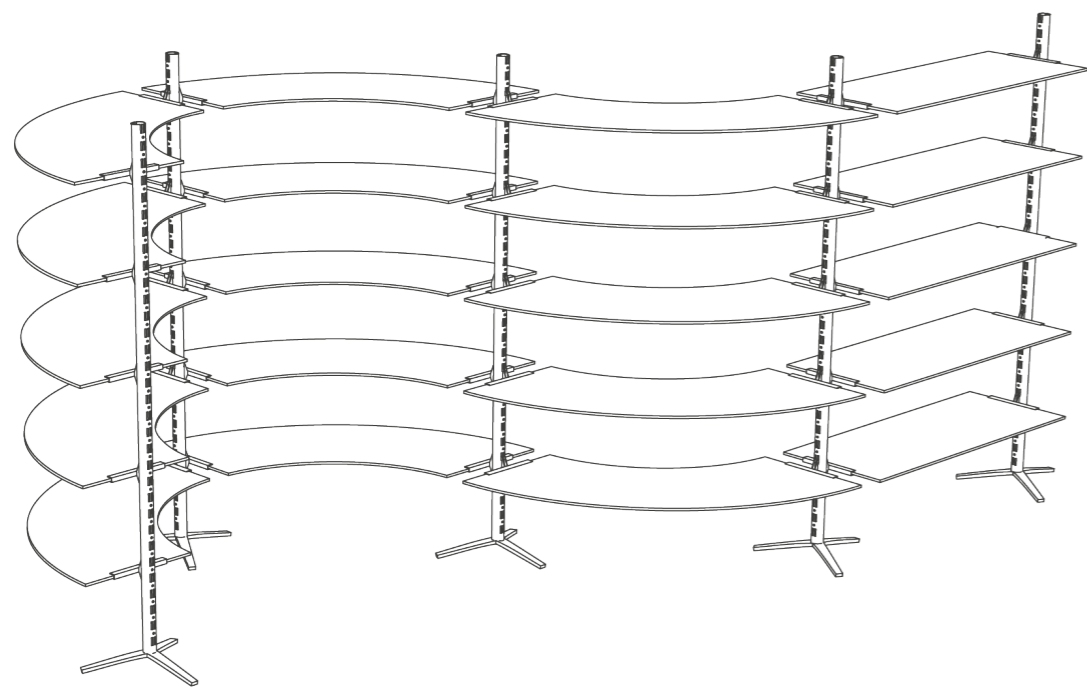

cod.STR FAR 001
PIANTANA H160

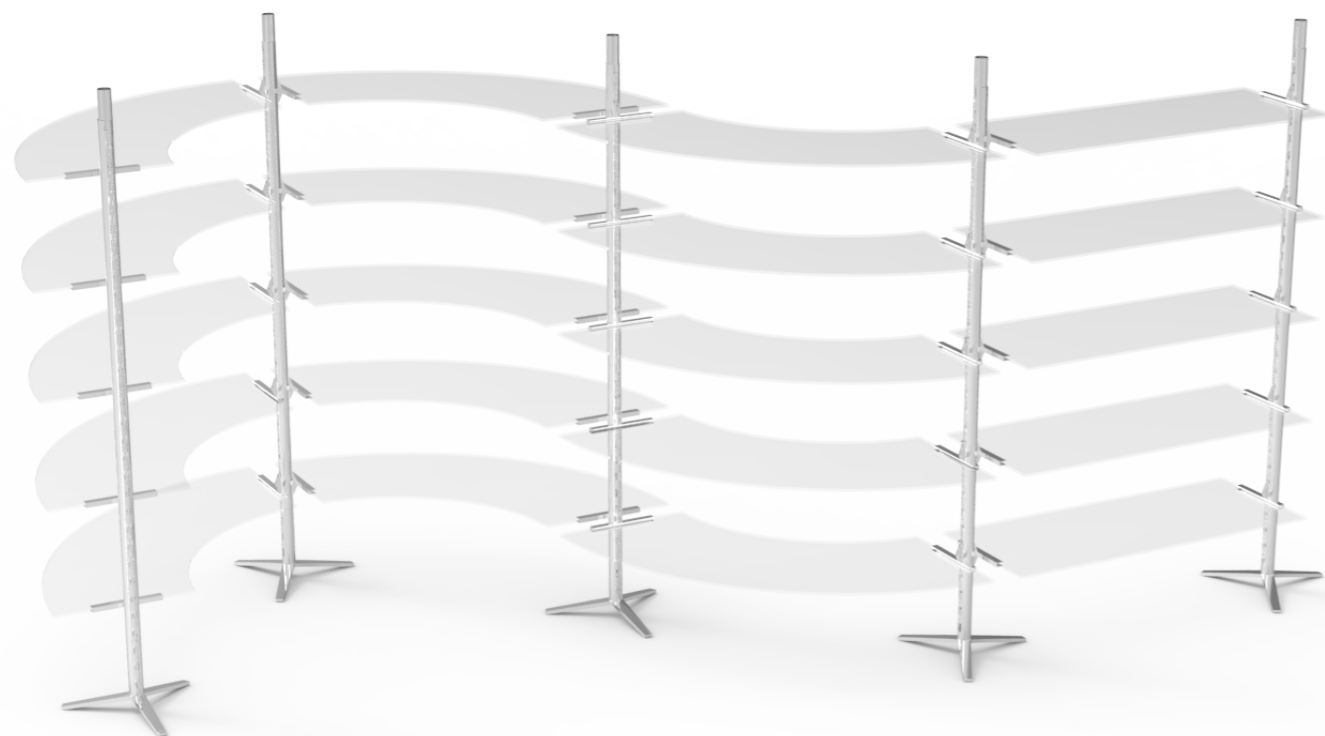
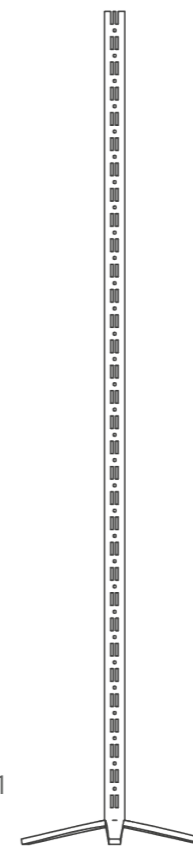

cod.STR FAR 002
RIPIANO CURVO IN VETRO
TRASPARENTE TEMPERATO
P400 L940



cod.STR FAR 003
RIPIANO DRITTO IN VETRO
TRASPARENTE TEMPERATO
P400 L1000

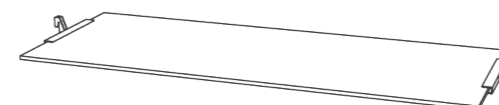

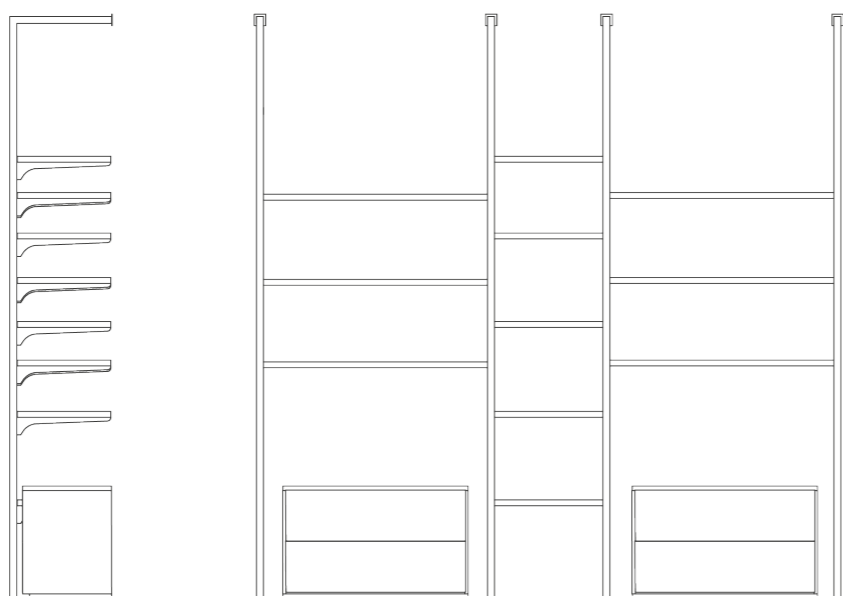

cod.STR FA SQ 032 K
MONTANTE H2400 P430

cod.STR FA CY 004.6 K
RIPIANO L1000 P380
cod.STR FA CY 004.8 K
RIPIANO INCLINATO L1000 P380

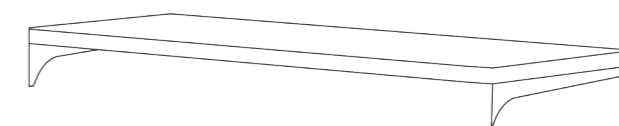

cod.STR FA CY 004.5 K
RIPIANO L500 P380
cod.STR FA CY 004.7 K
RIPIANO INCLINATO L500 P380

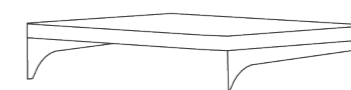

cod.STR ACC 014.1
CASSETTIERA 2 CASSETTI
L800 P400 H480

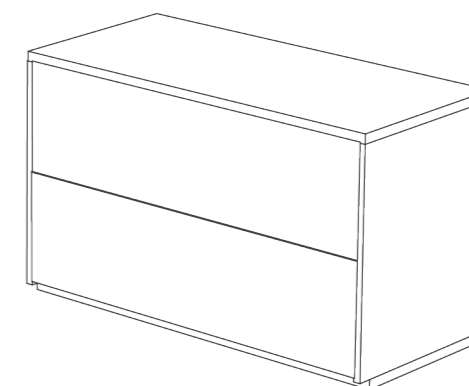

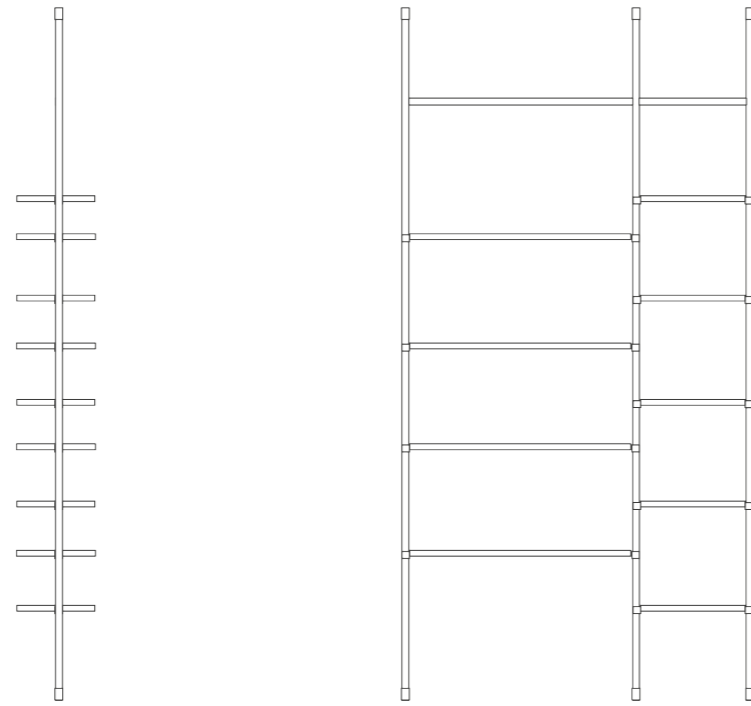

cod.STR FA SQ 038 K
MONTANTE H3000

cod.STR FA SQ 039.1
RIPIANO
L500 P400



cod.STR FA SQ 049.1
BARRA PER GRAFICA
L500

cod.STR FA SQ 049.1
BARRA PER GRAFICA
L1000



cod.STR FA SQ 039.2
RIPIANO
L1000 P400

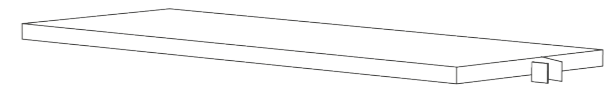

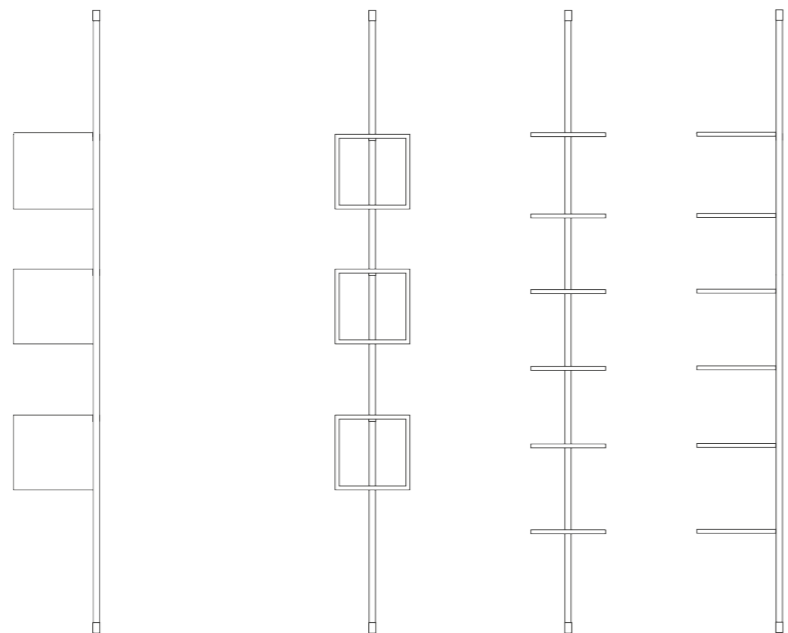

cod.STR FA SQ 038 K
MONTANTE H3000

cod.STR FA SQ 042 K
RIPIANO
340X340



cod.STR FA SQ 043 K
NICCHIA
340X340 H360

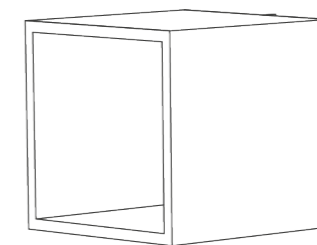

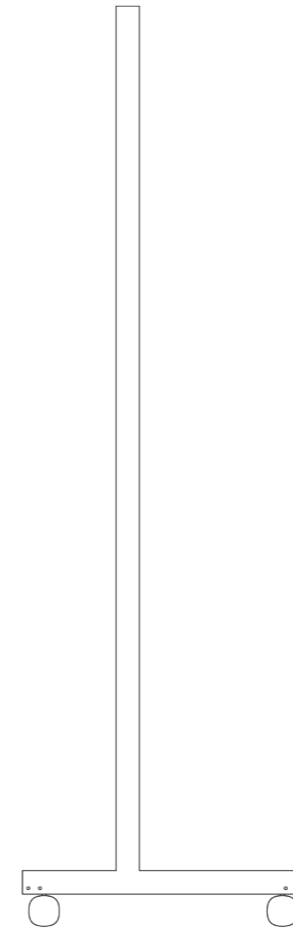
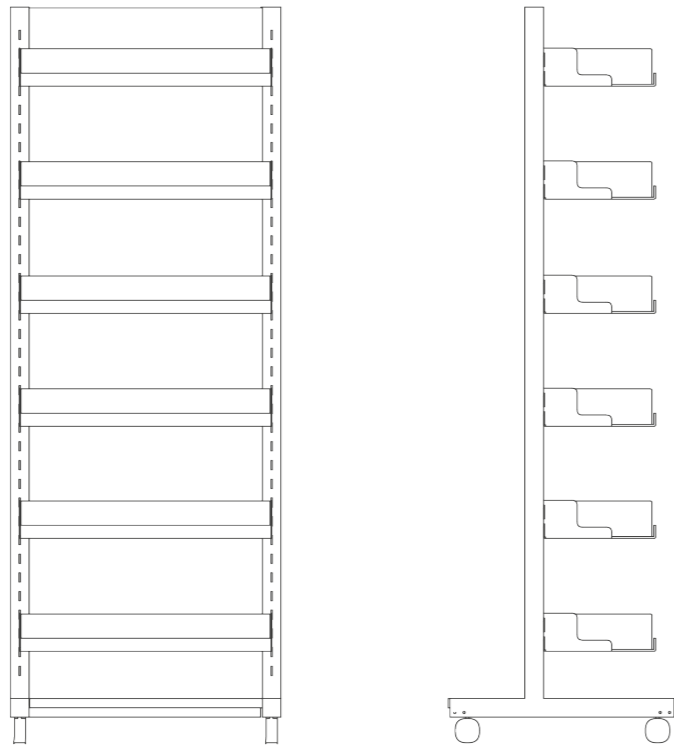

cod.STR FAR 004
MONTANTE CON RUOTE
H1950

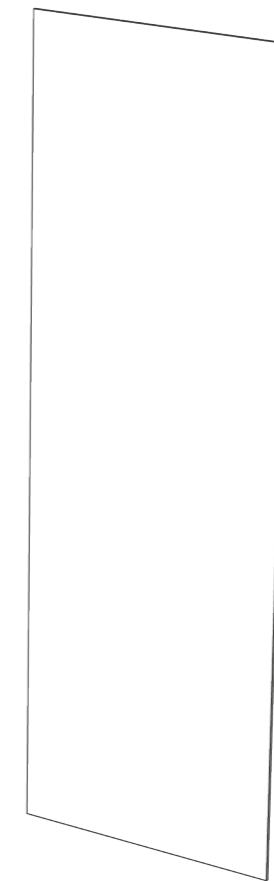

cod.STR FAR 005
SCHIENALE METALLO
L642 H1866

cod.STR FAR 006
PIANO BASE 658X600 H25

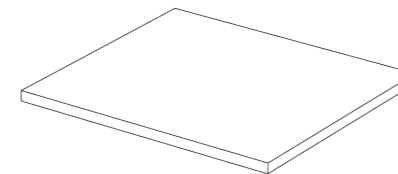

cod.STR FAR 007
RIPIANO METALLO REGOLABILE
L671 P300 H100

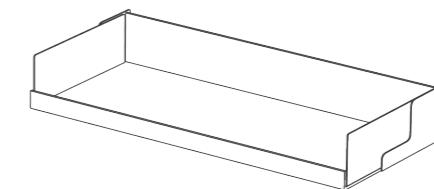

cod.STR FAR 008
BARRA DI RACCORDO
L642

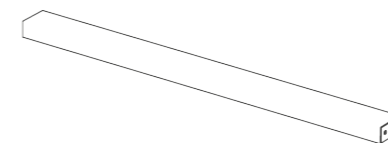

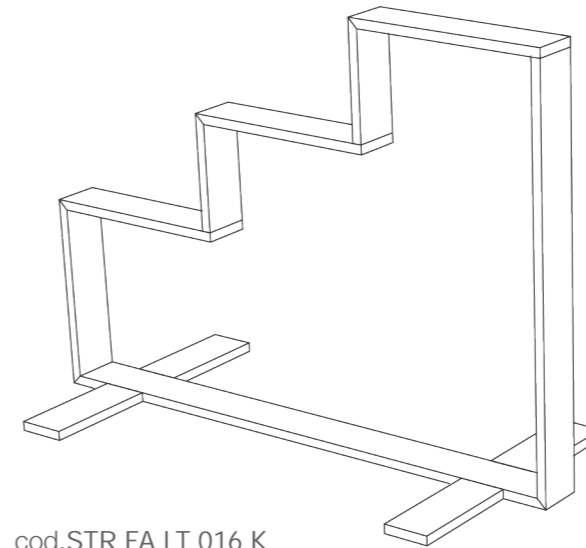

cod.STR FA LT 016 K
STRUTTURA IN TUBOLARE SU TRE LIVELLI

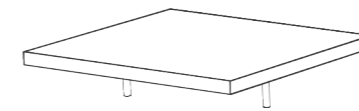

cod.STR FA LT 018 K
RIPIANO METALLO

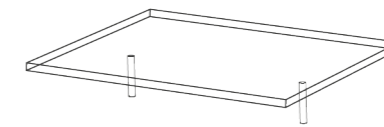

cod.STR FA LT 017 K
RIPIANO VETRO

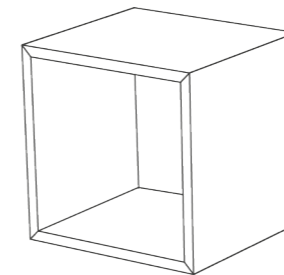

cod.STR FA LT 009 K
NICCHIA IN LEGNO

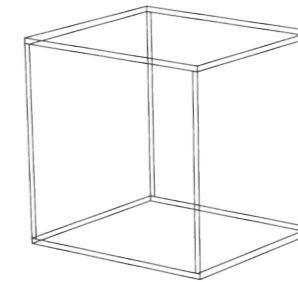

cod.STR FA LT 010 K
NICCHIA IN PLEXIGLASS



cod.STR FA LT 019
PANNELLO IN NOBILITATO
250X370h

cod.STR FA LT 019.1
PANNELLO IN NOBILITATO
250X640h

cod.STR FA LT 019.2
PANNELLO IN NOBILITATO
250X870h





 CRC srl - Viale 5 Giornate 1382
21042 Caronno Pertusella (VA)

 Tel. +39 02-96.59.001-2-3

 Fax. +39 02-96.59.004

 Skype: Crc Arredamenti

 Email: crc@crc.it

 www.arredamentifarmaciacrc.it

 Numero Verde
800.685.584